

WORKHORSE™ 50

NEW 50-FLD • Flat Level Deck • Hydraulic gooseneck • Fixed bogie

FONTAINE®
HEAVY-HAUL

**The durability you need.
The performance
you demand.**

- 50 tons capacity in 12 ft.
52 tons frame capacity in 16 ft.
(Configuration, GAWR, and tire ratings determine legal payloads)
- Fastest, most versatile hydraulic removable gooseneck in the industry ... You can connect or disconnect on uneven ground!
- 5-Position front ride-height adjustment
- 20" loaded deck height with 6" ground clearance
- 102" swing radius for easy maneuverability
- 24 ft. clear deck length—use every inch
- Boom trough with V-pan in bogie helps you get under bridges
- 5-Position mechanical ride height control system and dump valve for added convenience
- LED lights, strobes, and D-rings are all standard to give you more trailer for your money

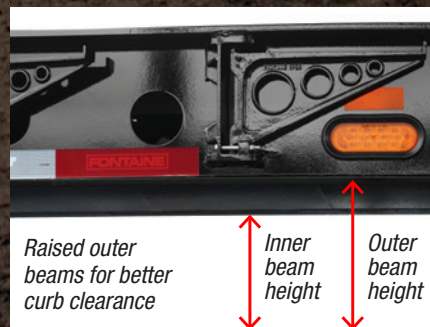
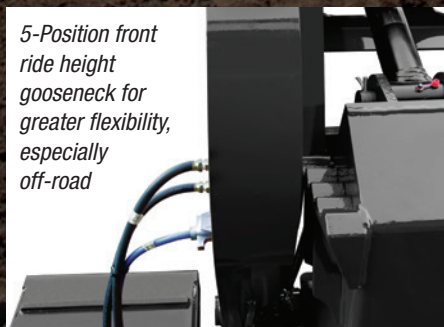

www.fontaineheavyhaul.com

Fontaine Heavy-Haul • 5398 US Highway 11 • Springville, AL 35146 • 205-467-6171

Weights shown are without options • Photos may show some optional equipment • Specifications subject to change without notice

Fontaine Workhorse™ 50 FLD Specifications

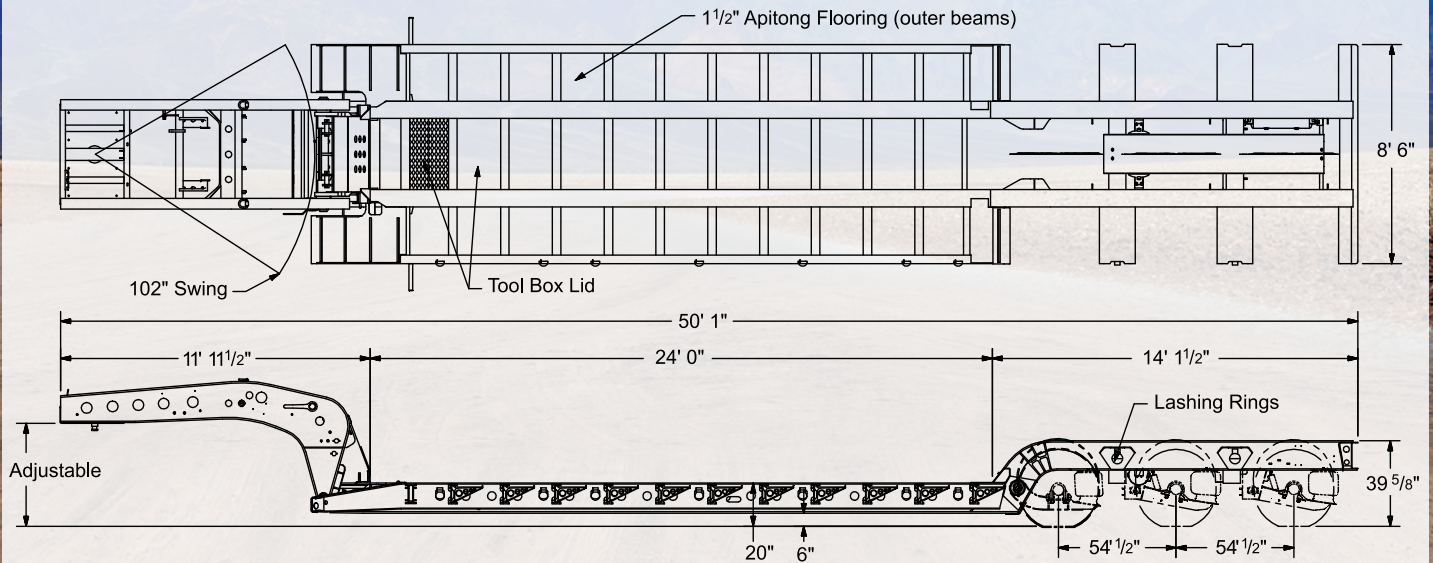

CAPACITY

- 50 tons capacity in 12'
- 52 tons frame capacity in 16'
- (Configuration, GAWR, and tire ratings determine legal payloads)

MAIN BEAMS

- All main longitudinal members fabricated with 100 KSI minimum yield steel flanges with 50,000 lb. webs

GOOSENECK FEATURES

- Hydraulic removable non-ground bearing
- 5-Position front ride-height adjustments (dual cam pawl option available for 7-Positions)
- 50" loaded fifth wheel height
- 102" swing radius
- Set up for wet line operation (optional gasoline powered auxiliary power unit available)
- J560 7-pin electrical connector

DECK FEATURES

- 8' 6" overall width
- 24' clear deck length
- 20" loaded deck height with 6" ground clearance
- 1 1/2" apitong flooring on side rails
- Two fully covered tool box trays with lockable covers in front of deck between mainbeams
- Manual front approach ramps standard (optional hinged front approach ramps with risers available)
- Extension brackets:
 - 12 pair (24 total) removable swing type
 - 1 pair (2 total) heavy-duty removable hook-on type
- Fixed deck to bogie connection

BOGIE FEATURES

- 3 axle bogie (dust shield option available)
- 25,000 lbs. nominal capacity per axle (GAWR determined by suspension type, brakes, tires and other components)
- Axle spread: 54.5" between axle centers (optional 60" axle spread available)
- Recessed load bearing bolsters between all axles and rear of last axle (optional load bearing wheel covers available)
- Unitized air-ride suspension with automatic and manual controls
- Air-lift third axle
- 5-Position rear ride-height control system with mechanical control valve
- Manual dump valve (Push/Pull)
- V-style boom trough with bolt-in V pan
- Heavy duty V-style rear bumper
- Rear Bogie Height: 40" to top flange
- Bogie width: 8' 6"

BRAKES (continued)

- 16 1/2" x 7" brakes with 5 1/2" autoslacks
- Heavy-duty brake drums, outboard mount

BRAKES (continued)

- Quick change replacement feature
- Automatic slack adjusters
- 4S2M ABS optional

WHEELS/TIRES

- Wheels: 8.25 x 22.5 steel disc, hub-piloted (optional aluminum wheels available)
- Tires: 255/70R 22.5 OEM Standard

ELECTRICAL SYSTEM

- Sealed harness for maximum corrosion resistance
- DOT sealed beam with LED lights
- 4" flush mounted, battery powered amber strobes

PROTECTIVE COATING

- Highest quality 2-part polyurethane enamel fights corrosion to extend the life of your trailer
- Primed for better paint adhesion

LASH RINGS

- 18 total D-Rings; 9 pair bent type for longer chain life and better securement

FLAG HOLDERS

- Located at front of deck and on rear bumper

ESTIMATED EMPTY WEIGHT W/O OPTIONS

18,720 lbs. ± 3%



Specifications subject to change without notice.
Photos show some optional equipment.

www.fontaineheavyhaul.com

Fontaine Heavy-Haul • 5398 US Highway 11 • Springville, AL 35146 • 205-467-6171

Weights shown are without options • Photos may show some optional equipment • Specifications subject to change without notice